



Clearview[®] COMPLETE HIV 1/2

Read this Product Insert completely before using the product. Follow the instructions carefully when performing the test as not doing so may result in inaccurate Test Results. Users of this test should follow the CDC Universal Precautions for prevention of transmission of Human Immunodeficiency Virus, Hepatitis B Virus, and other blood borne pathogens.¹

Storage: Store at 8° to 30°C (46° to 86°F)

NAME AND INTENDED USE

The Clearview[®] COMPLETE HIV 1/2 assay is a single-use immunochromatographic test for the detection of antibodies to Human Immunodeficiency Virus Types 1 (HIV-1) and Type 2 (HIV-2) in fingerstick whole blood, venous whole blood, and serum or plasma specimens. The Clearview COMPLETE HIV 1/2 assay is intended for use as a point-of-care test to aid in the diagnosis of infection with HIV-1 and HIV-2. This test is suitable for use in multi-test algorithms designed for the statistical validation of rapid HIV test results. When multiple rapid HIV tests are available, this test should be used in appropriate multi-test algorithms. For *in vitro* Diagnostics use only.

SUMMARY AND EXPLANATION OF THE TEST

Discovered in 1983, the Human Immunodeficiency Virus is a retrovirus and identified as the etiologic agent for the Acquired Immunodeficiency Syndrome (AIDS), and AIDS related complex². AIDS is characterized by changes in the population of T-cell lymphocytes that play a key role in the immune defense system. In the infected individual the virus causes a depletion of a subpopulation of T-cells, called T-helper cells, which leaves these patients susceptible to opportunistic infections and certain malignancies. The major routes of transmission are sexual contact, exposure to contaminated blood or blood products (including sharing of contaminated syringes and needles) and mother-to-newborn transmission.³⁻⁵

Although there has been a decrease in the rate of infection in certain countries, the number of persons infected with HIV globally has continued to increase. By the end of 2005 there were approximately 40.3 million people living with HIV/AIDS, an increase from nearly 37.5 million in 2003. An estimated 5 million people were newly infected with HIV in 2005. In the same year more than 3 million died of AIDS-related illness; more than 500,000 of these were children.⁶

HIV infection, AIDS and AIDS related complex have become a leading cause of illness and death in the United States for the past two decades. As of December 2001, a total of 774,467 persons were reported with AIDS and 448,060 of these persons had died. Approximately 800,000 - 900,000 persons in the United States are infected with HIV and approximately 80,000 - 280,000 of these persons may not be aware of their infected status.⁷

The HIV virus consists of a genomic RNA molecule protected by a capsid and an envelope. The HIV envelope is the major target for a humoral antibody response. The presence of the virus in patients causes the immune system to elicit the production of antibodies. The detection of these antibodies can be used as a diagnostic tool.

Enzyme Immunoassays (EIAs), Western Blots (WB), Nucleic Acid Amplification Test (NAT) assays and various other test systems are currently available for detection of HIV-1 and HIV-2 infection.⁸⁻¹² The Clearview COMPLETE HIV 1/2 assay utilizes immobilized antigens for the detection of antibodies to HIV-1 and HIV-2, and is a point-of-care test to aid in the diagnosis of infection with HIV-1 and HIV-2.

TEST PRINCIPLE

The Clearview COMPLETE HIV 1/2 assay employs a unique combination of a specific antibody binding protein which is conjugated to colloidal gold dye particles, and HIV-1/2 antigens which are bound to the solid phase membrane. The venous or capillary (fingerstick) whole blood, serum or plasma is applied to the capillary tip of the Sampler of test device. The Sampler is inserted into the Buffer, which is provided in a sealed vial. The Buffer facilitates the lateral flow of the specimen and test reagents and promotes the binding of the antibodies to the antigen. The specimen/buffer mixture migrates along the test strip by capillary action, reconstituting the conjugate. If present, the antibodies bind to the colloidal gold conjugated antibody binding protein. In a reactive sample, the dye conjugated-immune complex migrates on the nitrocellulose membrane and is captured by the antigens immobilized in the TEST area producing a pink/purple line. In the absence of HIV-1 and HIV-2 antibodies, there is no pink/purple line in the TEST area. The sample continues to migrate along the membrane and produces a pink/purple line in the CONTROL area containing immunoglobulin G antigens. This procedural control serves to demonstrate that specimen and reagents have been properly applied and have migrated through the device.



MATERIALS PROVIDED

Each Kit contains the components to perform 25 tests:

- 1 Product Insert for the Clearview COMPLETE HIV 1/2 assay
- 1 Disposable Rack for holding Buffer Vials upright
- 25 Pouches, each containing:
 - Sampler with a Test Strip inside (A)
 - Buffer Vial attached to the Sampler (~350µL) (B)
 - Sterile Safety Lancet (C)
 - Bandage (D)
 - Desiccant Packet (E)

MATERIALS REQUIRED BUT NOT PROVIDED

- Clock, watch, or other timing device
- Pipettor capable of delivering 2.5µL of sample (for other than fingerstick whole blood specimens)
- Disposable gloves
- Sterile gauze
- Antiseptic wipes
- Biohazard disposal container
- Collection devices for samples other than fingerstick whole blood specimens

WARNINGS

For *IN VITRO* diagnostic use

1. Read the Product Insert completely before using this assay. Follow the instructions carefully as not doing so may result in inaccurate Test Results.
2. Users of this test should follow the CDC Universal Precautions for prevention of transmission of Human Immunodeficiency Virus, Hepatitis B Virus, and other bloodborne pathogens.¹
3. Use of this test Kit with specimen types other than those specifically approved for use with this device may result in inaccurate Test Results.
4. This test should be performed at 18 to 30°C (64 to 86°F). If stored refrigerated, ensure that the pouch is brought to operating temperature before performing testing.
5. If the test Kit is stored at temperatures outside the storage temperature 8 to 30°C (46 to 86°F), or used outside the operating temperature 18 to 30°C (64 to 86°F), use the Kit Controls to ensure proper performance of the test.
6. Individual infected with HIV-1 and/or HIV-2 who is receiving highly active antiretroviral therapy (HAART) may produce false negative results.

PRECAUTIONS

SAFETY PRECAUTIONS

1. Handle the specimens and materials contacting specimens as if capable of transmitting infection.
2. Do not eat, drink or smoke in the area where specimens and kit reagents are handled. Avoid any contact with hands, eyes or mouth during specimen collection and testing.
3. Wear protective clothing such as laboratory coats, disposable gloves and eye protection when handling specimens.
4. Dispose of all specimens and materials used in the test procedure in a biohazard waste container. Lancets should be placed in a puncture-resistant container prior to disposal. The recommended method of disposal of biohazard waste is autoclaving for a minimum of 1 hour at 121°C. Disposable materials may be incinerated. Liquid wastes may be mixed with appropriate chemical disinfectants. A freshly prepared solution of 10% bleach (0.5% solution of sodium hypochlorite) is recommended. Allow 60 minutes for effective decontamination. NOTE: Do not autoclave solutions that contain bleach.
5. Use 10% bleach or other appropriate disinfectant to wipe all spills. The bleach solution should be made fresh each day.

HANDLING PRECAUTIONS

1. The Clearview COMPLETE HIV 1/2 assay device has a sample filter in the lower part of the device and an absorbent pad in the upper part of the device within the barrel that encloses the test strip. Confirm the presence of the sample filter and absorbent pad prior to performing the test. If either is missing, DO NOT USE.
2. Do not use any device if the pouch has been perforated. Do not use the device if the Desiccant Packet is missing.
3. Each device is for single use only.
4. Do not use the reagents beyond the expiration date printed on the pouch. Always check expiration date prior to testing.
5. Do not mix reagents from different lot numbers of Kits.
6. To ensure accurate Test Results, the Sampler must be inserted into the Buffer Vial immediately after the sample application.
7. Adequate lighting is required to read the Test Results.

STORAGE

The Clearview COMPLETE HIV 1/2 assay should be stored in its unopened pouch at 8 to 30°C (46 to 86°F). Do not freeze. Do not open the pouch until you are ready to perform a test. When stored as indicated, test devices are stable until the expiration date marked on the pouch.

SPECIMEN COLLECTION

The Clearview COMPLETE HIV 1/2 assay is performed on fingerstick whole blood, venous whole blood, serum or plasma specimens.

FINGERSTICK WHOLE BLOOD:

Prepare to perform the fingerstick blood collection procedure. Clean the finger of the person being tested with an antiseptic wipe. Allow the finger to dry thoroughly or wipe dry with a sterile gauze pad. Using a sterile lancet, puncture the skin just off the center of the finger and wipe away the first drop with sterile gauze and avoid squeezing the fingertip to accelerate bleeding as this may dilute the blood with excess tissue fluid. Collect the sample from the second drop touching the Sampler tip of the device to the drop of blood until the Sampler tip is full. Test immediately, following Test Procedure Instructions.

VENOUS WHOLE BLOOD:

Draw blood following laboratory procedures for obtaining venous blood. Collect sample in a tube containing citrate, heparin, or EDTA. Be sure the tube of blood is well mixed.

SERUM OR PLASMA:

Draw blood following laboratory procedures for obtaining serum or plasma specimens. Collect specimen in a tube not containing any anticoagulant (serum), and in a tube containing citrate, heparin, or EDTA (plasma). Collect specimen in a clean container following standard laboratory procedures.

Venous whole blood, serum and plasma specimens may be tested immediately after collection. If specimens are not tested immediately, refrigerate them at 2 to 8°C (36 to 46°F) following collection. These specimens should be tested within 3 days of collection. If specimens are not tested within 3 days of collection, serum or plasma specimens should be frozen at -20°C (-4°F) or colder. **DO NOT FREEZE WHOLE BLOOD!**

SPECIMEN SHIPPING

If specimens are to be shipped, they should be packed in compliance with regulations covering the transportation of etiologic agents. Venous whole blood, serum and plasma specimens should be shipped refrigerated with cold packs or wet ice.

TEST PROCEDURE

KIT COMPONENT PREPARATION

All components for the Clearview COMPLETE HIV 1/2 assay are ready to use as supplied. Follow directions as indicated. If the specimen to be tested is refrigerated, remove it from the refrigerator and allow it to come to a temperature of 18 to 30°C: (64 to 86°F) prior to testing.

1. OPEN POUCH AND REMOVE COMPONENTS

Remove Buffer Vial - Separate from top of Sampler and place in Disposable Rack.

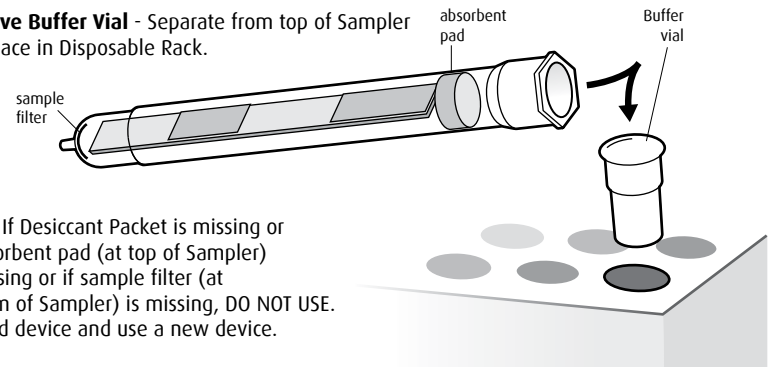

Note: If Desiccant Packet is missing or if absorbent pad (at top of Sampler) is missing or if sample filter (at bottom of Sampler) is missing, DO NOT USE. Discard device and use a new device.

2. SPECIMEN APPLICATION

For fingerstick whole blood, touch blood drop with Sampler tip until the tip is full.

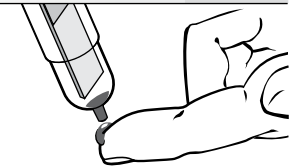

OR

For venous whole blood, serum or plasma, invert Sampler and pipet 2.5µL of specimen into sampler tip.



3. START THE TEST

- With Buffer Vial in rack, firmly press the Sampler tip through foil cover.
- Continue pushing to the bottom of the vial until Sampler and Buffer Vial snap together tightly.

It will “snap” 3 times when properly seated.

- Snap 1: through foil
- Snap 2: into cap
- Snap 3: seat and seal

CAUTION: When inserting tip through foil cover, push gently to puncture foil, but do not jab into foil cover.

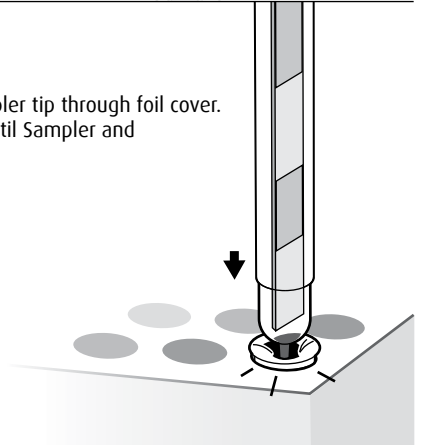

4. START TIMING - WAIT FOR 15 MINUTES

NOTE: the Sampler/ Buffer Vial should be kept upright in the Disposable Rack



5. READ TEST RESULTS

Read the test between 15 and 20 minutes.

NOTE: Reactive Test Results (See Interpretation of Test Results section) may be observed and read earlier than 15 minutes. To verify a Nonreactive Test Result, wait the entire 15 minutes after starting the test.

Do not read results after 20 minutes.

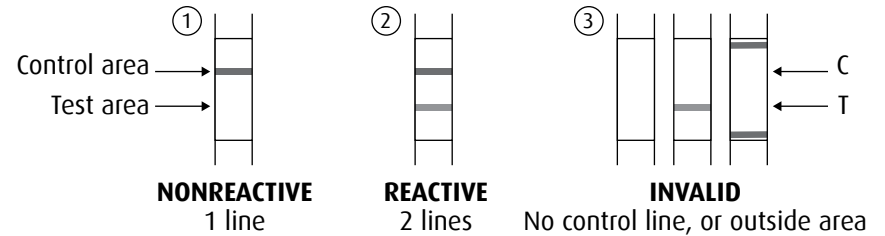
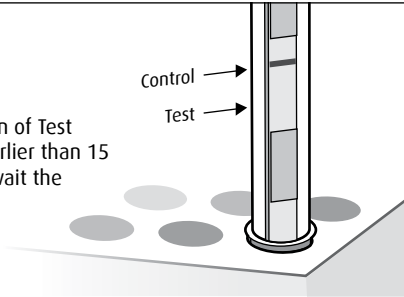

QUALITY CONTROL

BUILT-IN CONTROL FEATURE

The control line serves as a built-in internal control and gives confirmation of sample addition and proper test performance. A pink/purple line will appear in the CONTROL area if the test has been performed correctly and the device is working properly (Please see section: Interpretation of Test Results).

INTERPRETATION OF TEST RESULTS

When the Clearview COMPLETE HIV 1/2 assay is properly performed, the appropriate pink/purple lines will become visible. These are:

1. **The CONTROL LINE** - which appears closer to the top of the test strip, indicates that specimen was adequately applied, and there was proper hydration and migration of reagents. The control line will become visible within 15 minutes after starting the test regardless of the HIV antibody status of the specimen.
2. **The TEST LINE** - which appears closer to the bottom of the test strip (below the control line) indicates the presence of HIV-specific antibodies. The test line will only become visible within 15 minutes after starting a valid test when HIV specific antibodies are present at detectable levels in the specimen.

NONREACTIVE (diagram 1):

One pink/purple line in the CONTROL area, with no line in the TEST area indicates a NONREACTIVE Test Result. A NONREACTIVE Test Result means that HIV-1 and HIV-2 antibodies were not detected in the specimen. The Test Result is interpreted as NEGATIVE for HIV-1 and HIV-2 antibodies. However, this does not exclude possible infection with HIV. Follow CDC guidelines to inform the test subject of the Test Result and its interpretation.^{7,13}

REACTIVE (diagram 2):

Two pink/purple lines, one in the TEST area and one in the CONTROL area indicate a REACTIVE Test Result. The line in the TEST area may look different from the line in the CONTROL area. Intensities of the Test and Control Lines may vary. Test Result with visible lines in both TEST and CONTROL areas, regardless of intensity, is considered REACTIVE. A REACTIVE Test Result means that HIV-1 and/or HIV-2 antibodies have been detected in the specimen. The Test Result is interpreted as Preliminary POSITIVE for HIV-1 and/or HIV-2 antibodies. Follow CDC guidelines to inform the test subject of the Test Result and its interpretation.^{7,13}

INVALID (diagram 3):

A pink/purple line should always appear in the CONTROL area, whether or not a line appears in the TEST area. If there is no distinct pink/purple line visible in the CONTROL area (see diagrams 1 and 2), then the test is INVALID. Any line that appears outside of the Control Area or Test Area (see diagram 3) is an INVALID test. An INVALID test cannot be interpreted. It is recommended that the INVALID test be repeated with a new device.

LIMITATIONS OF THE PROCEDURE

1. The Clearview COMPLETE HIV 1/2 test must be used in accordance with the instructions in this Product Insert to obtain accurate results.
2. The Clearview COMPLETE HIV 1/2 assay must be used with capillary (fingerstick) or venous whole blood, serum or plasma only. Use of other types of specimens or testing of venipuncture whole blood specimens collected using a tube containing an anticoagulant other than citrate, heparin or EDTA may not yield accurate results. For serum samples, collect blood without anticoagulant.
3. Reading Nonreactive Test Results earlier than 15 minutes or any Test Result later than 20 minutes may yield erroneous results.
4. Do not open the sealed foil pouch until just prior to use.
5. Do not use Kit contents beyond labeled expiration date.
6. For the collection of the fingerstick whole blood specimen, ensure that finger is completely dry before performing fingerstick.
7. Read results in a well-lit area.
8. A Reactive Test Result using the Clearview COMPLETE HIV 1/2 test suggests the presence of antibodies to HIV-1 and/or HIV-2 in the specimen. The Clearview COMPLETE HIV 1/2 assay is intended as an aid in the diagnosis of infection with HIV-1/2. AIDS and AIDS-related conditions are clinical syndromes and their diagnosis can only be established clinically.
9. For a Reactive Test Result, the intensity of the test line does not necessarily correlate with the titer of antibody in the specimen.
10. A person who has antibodies to HIV-1 or HIV-2 is presumed to be infected with the virus, except that a person who has participated in an HIV vaccine study may develop antibodies to the vaccine and may or may not be infected with HIV.
11. A Nonreactive Test Result does not preclude the possibility of exposure to HIV or infection with HIV. An antibody response to recent exposure may take several months to reach detectable levels.
12. This assay has not been evaluated for newborn screening, cord blood specimens, or individuals less than 18 years and greater than 64 years of age.

PERFORMANCE CHARACTERISTICS

The Clearview COMPLETE HIV 1/2 assay was evaluated in prospective clinical studies at four geographically distinct sites. The specimens were tested from three groups of individuals: Known infected with HIV-1, at high risk for infection with HIV-1, and at low risk for infection with HIV-1. The Clearview COMPLETE HIV 1/2 assay was tested in parallel on fingerstick whole blood, venous whole blood, serum and plasma specimen matrices. No discordant result was obtained from all specimen matrices. The serum/plasma specimens from study subjects were also tested using a licensed Enzyme Immunoassay (EIA). Specimens with discordant results were further tested using licensed Western Blot and/or FDA approved Nucleic Acid Testing (NAT) assay.

SENSITIVITY

The sensitivity of the Clearview COMPLETE HIV 1/2 assay to detect infection with HIV-1 was evaluated using 604 specimens from individuals known to be infected with HIV-1 and from 776 individuals at high risk for infection with HIV-1 (Table 1). 638 individuals were identified as positive for infection with HIV-1 using a licensed confirmatory assay, and/or FDA approved NAT assay. Of these, 636 specimens tested reactive on the Clearview COMPLETE HIV 1/2 assay. The calculated sensitivity of Clearview COMPLETE HIV 1/2 assay in these studies was 99.7% (636/638 = 99.7% with 95% CI = 98.9% - 100%).

TABLE 1

Detection of antibody to HIV-1 in specimens from individuals known to be infected with HIV-1, and at high risk for infection with HIV-1

Study Population	Samples	Clearview COMPLETE HIV 1/2 Reactive	Licensed EIA Repeatedly Reactive	Licensed WB Reactive	True Positive ¹
Known Positive	604	600	602	602	602
High-Risk	776	36	41	35 ²	36 ³
Total	1380	636	643	637	638

1. Based on licensed WB and NAT assay results (when positive and EIA is repeatedly reactive).
2. Two specimens were indeterminate by Western Blot (one was initially reactive only on EIA and nonreactive on Clearview COMPLETE HIV 1/2, and one was repeatedly reactive on EIA and nonreactive on Clearview COMPLETE HIV 1/2).
3. One specimen was repeatedly reactive on EIA and reactive on Clearview COMPLETE HIV 1/2, indeterminate on WB, and positive on NAT.

The sensitivity of the Clearview COMPLETE HIV 1/2 assay to detect HIV-2 antibody was determined by testing 202 serum/plasma specimens that were positive for HIV-2 antibodies only. These specimens were obtained from repository sources. A total of 488 specimens from an area endemic for HIV-2 infection were also tested (Table 2). All specimens reactive with the Clearview COMPLETE HIV 1/2 in these studies were also reactive by a licensed anti-HIV-1/2 EIA. The sensitivity of Clearview HIV-1/2 for the detection of antibodies to HIV-2 in these studies was calculated to be 100% (203/203 = 100% with 95% CI = 98.2% - 100%).

TABLE 2

Detection of antibody to HIV-2 in known HIV-2 reactive specimens and endemic samples

Study Population	Samples	Clearview COMPLETE HIV 1/2 Reactive	True HIV-2 Positive Only ¹
Known HIV-2 Positive	202	202	202
Endemic Samples	488	27 ²	1
TOTAL	690	229	203

1. Confirmation based on results using a research use HIV-2 Western blot.
2. Of these 27 HIV-1 EIA and HIV-2 EIA reactive specimens; 23 were reactive on HIV-1 WB only, three were reactive on HIV-1 and HIV-2 WB, and one was indeterminate on HIV-1 WB and reactive on HIV-2 WB.

REACTIVITY WITH HIV-1 SPECIMENS FROM VARIOUS WORLD WIDE GEOGRAPHIC REGIONS

To assess sensitivity of the Clearview COMPLETE HIV 1/2 assay for HIV-1 specimens from various worldwide geographic regions, 750 confirmed HIV antibody-positive specimens were obtained. Of the 715 specimens evaluated from Africa, Asia, Latin America, Europe, and Belgium, 712 were reactive using Clearview COMPLETE HIV 1/2. The remaining 35 confirmed positive specimens from two worldwide panels were evaluated, consisting of naturally occurring plasma specimens from diverse geographical locations (Spain, Ghana, Cote d' Ivoire, Mozambique, Uganda, Zimbabwe, China, Thailand, India, USA and Argentina with HIV-1 genotypes: A, B, C, D, E, F, G, O, B/D and HIV-2). All 35 were reactive using Clearview COMPLETE HIV 1/2 assay.

REACTIVITY WITH SEROCONVERSION PANELS

The Clearview COMPLETE HIV 1/2 assay was tested against 15 different seroconversion panels. Each panel consisted of sequential collections from a single individual who seroconverted. Samples were confirmed using Western Blot (WB) and two licensed EIA tests. As shown in Table 3, the Clearview COMPLETE HIV 1/2 test performed similarly to currently licensed assays in detecting seroconversion.

TABLE 3

Comparison of the Clearview COMPLETE HIV 1/2 assay to two licensed EIA assays and Western Blot in detecting seroconversion. (Where NR = Nonreactive and RR = Repeatedly Reactive)

Panel	Relative Day of Bleed	Clearview COMPLETE HIV 1/2	EIA 1	EIA 2	WB
PRB-927 (AB)	0	NR	NR	NR	NR
	28	NR	RR	NR	NR
	33	NR	RR	NR	NR
	35	R	RR	NR	NR
	40	R	RR	RR	R
PRB-928 (AC)	0	NR	NR	NR	NR

Panel	Relative Day of Bleed	COMPLETE HIV 1/2	EIA 1	EIA 2	WB
	111	NR	RR	NR	NR
	120	R	RR	RR	R
	125	R	RR	RR	R
	130	R	RR	RR	R
PRB-930 (AE)	0	NR	NR	NR	NR
	3	NR	NR	NR	NR
	7	NR	RR	NR	NR
	10	NR	RR	RR	IND
PRB-931 (AF)	0	NR	NR	NR	NR
	2	NR	NR	NR	NR
	7	NR	NR	NR	NR
	9	NR	NR	NR	NR
	15	NR	NR	NR	NR
	28	R	RR	NR	NR
	33	R	RR	RR	IND
	35	R	RR	RR	R
	42	R	RR	RR	R
PRB-934 (AI)	0	NR	NR	NR	NR
	7	R	RR	NR	IND
	11	R	RR	RR	IND
PRB-938 (AM)	0	NR	NR	NR	NR
	3	NR	NR	NR	NR
	9	NR	RR	NR	IND
PRB-944 (AT)	0	NR	NR	NR	NR
	2	NR	NR	NR	NR
	7	NR	NR	NR	NR
	9	NR	NR	NR	NR
	14	R	RR	NR	IND
	16	R	RR	NR	IND
PRB-959 (BI)	0	NR	NR	NR	NR
	7	NR	NR	NR	NR
	9	NR	RR	NR	NR
	14	R	RR	RR	R
	19	R	RR	RR	R
	21	R	RR	RR	R
	26	R	RR	RR	R

Panel	Relative Day of Bleed	COMPLETE HIV 1/2	EIA 1	EIA 2	WB
PRB-904 (D)	0	NR	NR	NR	NR
	21	NR	NR	NR	NR
	49	NR	NR	NR	NR
	92	R	RR	RR	R
	99	R	RR	RR	R
PRB-910 (J)	0	NR	NR	NR	NR
	14	R	NR	NR	NR
	26	R	RR	RR	R
	28	R	RR	RR	R
	32	R	RR	RR	R
	35	R	RR	RR	R
	40	R	RR	RR	R
PRB-914 (N)	0	R	RR	NR	IND
	4	R	RR	RR	IND
	7	R	RR	RR	IND
	25	R	RR	RR	R
	31	R	RR	RR	R
PRB-916 (P)	0	NR	NR	NR	NR
	4	NR	NR	NR	NR
	9	NR	NR	NR	NR
	15	NR	NR	NR	NR
	30	R	RR	RR	R
	35	R	RR	RR	R
PRB-917 (Q)	0	NR	NR	NR	NR
	53	NR	NR	NR	NR
	57	NR	NR	NR	NR
	60	N/A*	RR	NR	NR
	65	R	RR	NR	IND
	67	R	RR	NR	IND
	72	N/A*	RR	RR	R
PRB-919 (S)	0	NR	NR	NR	NR
	9	R	RR	NR	R
	11	R	RR	RR	R
PRB-922 (V)	0	NR	RR	NR	NR
	4	NR	RR	NR	NR
	7	R	RR	NR	NR
	11	R	RR	NR	R

* N/A – Not Available

REACTIVITY WITH HIV-1 LOW TITER PANELS

A total of 30 specimens from two characterized Low Titer panels were used to evaluate the ability of the Clearview COMPLETE HIV 1/2 assay to detect antibodies to HIV-1. The results of testing are presented in Table 4 and demonstrate that the Clearview COMPLETE HIV 1/2 assay detected the presence of antibody in a manner similarly to one or both of the licensed EIAs.

TABLE 4

Comparison of the Clearview COMPLETE HIV 1/2 assay to two licensed EIA assays and Western Blot using Low Titer panels (Where NR = Nonreactive and RR = Repeatedly Reactive)

Panel	COMPLETE HIV 1/2	EIA 1	EIA 2	WB
PRB107-1	NR	RR	NR	NR
PRB107-2	NR	RR	RR	IND
PRB107-3	NR	RR	NR	NR
PRB107-4	NR	RR	RR	NR
PRB107-5	NR	NR	NR	NR
PRB107-6	R	RR	RR	NR
PRB107-7	NR	RR	NR	NR
PRB107-8	NR	RR	RR	NR
PRB107-9	NR	RR	NR	NR
PRB107-10	R	RR	RR	NR
PRB107-11	R	RR	RR	R
PRB107-12	NR	RR	NR	NR
PRB107-13	NR	RR	NR	IND
PRB107-14	R	RR	RR	R
PRB107-15	R	RR	RR	IND
PRB108-1	R	RR	RR	R
PRB108-2	NR	NR	NR	NR
PRB108-3	NR	RR	RR	IND
PRB108-4	R	RR	RR	R
PRB108-5	R	RR	RR	R
PRB108-6	R	RR	RR	IND
PRB108-7	R	RR	RR	R
PRB108-8	R	RR	RR	R
PRB108-9	R	RR	RR	R
PRB108-10	NR	RR	NR	IND
PRB108-11	R	RR	RR	R
PRB108-12	NR	RR	NR	NR
PRB108-13	NR	RR	NR	IND
PRB108-14	NR	RR	NR	NR
PRB108-15	RR	RR	RR	IND

REACTIVITY WITH HIV-1 MIXED TITER PANELS

The sensitivity of Clearview COMPLETE HIV 1/2 assay was evaluated by testing three well characterized panels composed of specimens ranging from nonreactive to strong reactive for anti-HIV-1 antibody. The results are presented in Table 5 and indicate that the Clearview COMPLETE HIV 1/2 assay was able to detect antibodies to HIV-1 similarly to the licensed EIA and WB.

TABLE 5

Comparison of the Clearview COMPLETE HIV 1/2 assay to two licensed EIA assays and Western Blot using Mixed Titer Panels (Where NR = Nonreactive and RR = Repeatedly Reactive)

Panel	COMPLETE HIV 1/2	EIA 1	EIA 2	WB
PRB202-1	NR	RR	RR	IND
PRB202-2	R	RR	RR	R
PRB202-3	R	RR	RR	R
PRB202-4	R	RR	RR	R
PRB202-5	R	RR	RR	R
PRB202-6	R	RR	RR	R
PRB202-7	R	NR	RR	R
PRB202-8	R	RR	RR	R
PRB202-9	NR	NR	NR	NR
PRB202-10	R	RR	RR	R
PRB202-11	R	RR	RR	R
PRB202-12	R	RR	RR	R
PRB202-13	R	RR	RR	R
PRB202-14	R	RR	RR	R
PRB202-15	R	RR	RR	R
PRB202-16	R	RR	RR	R
PRB202-17	R	RR	RR	R
PRB202-18	R	RR	RR	R
PRB202-19	R	RR	RR	R
PRB202-20	R	RR	RR	R
PRB202-21	NR	NR	NR	NR
PRB202-22	R	RR	RR	R
PRB202-23	NR	RR	NR	IND
PRB202-24	R	RR	RR	R
PRB202-25	R	RR	RR	R
PRB203-1	R	RR	RR	R
PRB203-2	R	RR	RR	R
PRB203-3	NR	NR	NR	NR
PRB203-4	NR	RR	NR	IND
PRB203-5	R	RR	RR	R
PRB203-6	R	RR	RR	R
PRB203-7	R	RR	RR	R

Panel	COMPLETE HIV 1/2 assay	EIA 1	EIA 2	WB
PRB203-8	R	RR	RR	R
PRB203-9	R	RR	RR	R
PRB203-10	R	RR	RR	R
PRB203-11	R	RR	RR	R
PRB203-12	R	RR	RR	R
PRB203-13	R	RR	RR	R
PRB203-14	NR	RR	NR	NR
PRB203-15	R	RR	RR	R
PRB203-16	R	RR	RR	R
PRB203-17	R	RR	RR	R
PRB203-18	R	RR	RR	R
PRB203-19	R	RR	RR	R
PRB203-20	NR	NR	NR	NR
PRB203-21	R	RR	RR	R
PRB203-22	R	RR	RR	R
PRB203-23	R	RR	RR	R
PRB203-24	R	RR	RR	R
PRB203-25	R	RR	RR	R
PRB204-1	NR	RR	NR	NR
PRB204-2	R	RR	RR	R
PRB204-3	NR	NR	NR	NR
PRB204-4	R	RR	RR	R
PRB204-5	R	RR	RR	R
PRB204-6	R	RR	RR	R
PRB204-7	R	RR	RR	R
PRB204-8	R	RR	RR	R
PRB204-9	NR	RR	NR	NR
PRB204-10	R	RR	RR	IND
PRB204-11	R	RR	RR	R
PRB204-12	R	RR	RR	R
PRB204-13	NR	RR	RR	IND
PRB204-14	R	RR	RR	R
PRB204-15	R	RR	RR	R
PRB204-16	R	RR	RR	R
PRB204-17	R	RR	RR	R
PRB204-18	R	RR	RR	IND
PRB204-19	R	RR	RR	R
PRB204-20	R	RR	RR	R
PRB204-21	R	RR	RR	R
PRB204-22	R	RR	RR	R
PRB204-23	NR	NR	NR	NR
PRB204-24	NR	RR	NR	IND
PRB204-25	NR	RR	NR	IND

SPECIFICITY

The specificity of Clearview COMPLETE HIV 1/2 assay was evaluated by testing specimens from low risk and high risk populations for infection with HIV-1 from three clinical study sites. The results are summarized in Table 6.

TABLE 6

Performance of the Clearview COMPLETE HIV 1/2 assay on specimens from individuals presumed to be negative for HIV-1 infection

Study Population	Samples	Clearview COMPLETE HIV 1/2 assay Nonreactive	Licensed EIA Nonreactive	True Negative ¹
Low-Risk	691	690	687 ²	691
High-Risk	776	740	735 ³	740
Total	1467	1430	1422	1431

1. Confirmation performed by licensed HIV-1 Western Blot, IFA or NAT. One specimen was EIA repeatedly reactive, WB indeterminate, and NAT positive. One specimen was EIA repeatedly reactive and WB indeterminate. These two specimens were not included in the specificity calculations.
2. Four specimens were repeatedly reactive on EIA and nonreactive on Clearview COMPLETE HIV 1/2 assay and Western Blot.
3. Five specimens were repeatedly reactive on EIA and nonreactive on Clearview COMPLETE HIV 1/2 assay and Western Blot.

Based on these studies, the specificity of Clearview COMPLETE HIV 1/2 assay in these studies was calculated to be 99.9% (1430/1431 = 99.9% with 95% CI = 99.6% - 100%).

EFFECT OF POTENTIALLY INTERFERING SUBSTANCES AND UNRELATED MEDICAL CONDITIONS

To evaluate the influence of unrelated medical conditions or interfering substance on the specificity and sensitivity of the Clearview COMPLETE HIV 1/2 assay, 208 specimens representing unrelated medical conditions, and 110 specimens representing potential interfering substances were tested (Table 7). The specimens were spiked with either saline (Nonreactive) or an HIV-1 reactive serum specimen to a low level of reactivity. All HIV-1 spiked specimens gave reactive results, while all unspiked samples, with the exception of one elevated albumin specimen and 14 syphilis specimens, gave nonreactive results. The one elevated albumin specimen and all of the 14 unspiked syphilis specimens with reactive test results were subsequently confirmed as infected with HIV-1 using a licensed Western Blot assay. An additional ten known HIV-1 nonreactive, syphilis reactive specimens were tested and yielded expected results.

TABLE 7

Clearview COMPLETE HIV 1/2 assay reactivity against specimens from unrelated medical conditions or containing potential interfering substances.

Clearview COMPLETE HIV 1/2 assay		
Description	Saline (Nonreactive)	HIV-1/2 (Weak Reactive)
Cirrhosis	20 / 20	20 / 20
CMV IgM	20 / 20	20 / 20
Recent flu vaccination ¹	11 / 11	11 / 11
HBV	21 / 21	21 / 21
HCV	19 / 19	19 / 19
HTLV-I	11 / 11	11 / 11
HTLV-II	10 / 10	10 / 10
Multiparous	9 / 9	9 / 9
Myeloma	10 / 10	10 / 10
Rheumatoid Factor	10 / 10	10 / 10
Syphilis ²	15 / 29	29 / 29
Tuberculosis	38 / 38	38 / 38
Elevated Albumin ³	9 / 10	10 / 10
Elevated Bilirubin	10 / 10	10 / 10
Citrate	10 / 10	10 / 10
DNA	10 / 10	10 / 10
EDTA	10 / 10	10 / 10
Hemolyzed	10 / 10	10 / 10
Heparin	10 / 10	10 / 10
Icteric	10 / 10	10 / 10
Lipemic	10 / 10	10 / 10
Elevated Protein	10 / 10	10 / 10
Elevated Triglycerides	10 / 10	10 / 10

1. Collected within 6 months of vaccination
2. Fourteen samples were confirmed reactive, using a licensed WB assay
3. One sample was confirmed as containing HIV antibodies by using a licensed WB assay

REPRODUCIBILITY STUDIES

Reproducibility was tested at three independent sites using three lots of Clearview COMPLETE HIV 1/2 assay. A panel of five blinded samples representing nonreactive, low reactive HIV-1, low reactive HIV-2, high reactive HIV-1 and high reactive HIV-2 were run on three separate days by three separate technicians at each site. Testing was performed according to the Product Insert of the Clearview COMPLETE HIV 1/2 test. Results were read at 15 minutes. Results were read semi-quantitatively using a common strip evaluation scale. A total of 405 data points was taken. There was 100% reproducibility (405/405) across all parameters.

REFERENCES

1. Centers for Disease Control and Prevention (CDC) Universal Precautions for prevention of transmission of human immunodeficiency virus, hepatitis B virus, and other bloodborne pathogens in health-care settings. *MMWR* 1988; 37(24):377-388.
2. Essex, M. (1999) Human immunodeficiency viruses in the developing world. *Adv Virus Res* 53 : 71-88.
3. Kanki, P.J., Hopper, J.R. and Essex, M. (1987) The origins of HIV-1 and HTLV-4/HIV-2. *Ann N Y Acad Sci* 511 : 370-375.
4. Nicoll, A., Gill, O.N. (1999) The global impact of HIV infection and disease. *Commun Dis Publ Health* 2 : 85-95.
5. Valdiserri R.O., Holtgrave, D.R., West, G.R. (1999) Promoting early diagnosis and entry into care. *AIDS* 13 : 2317-2330.
6. UNAIDS / WHO Press Release (2005) HIV Infection Rates Decreasing in Several Countries but Globally Number of People Living with HIV Continue to Rise. Available at www.unaids.org/epi/2005/doc/docs/PR_EpiUpdateNov05en.pdf: 1-3.
7. CDC. Revised Guidelines for HIV Counseling, Testing and Referral and Revised Recommendations for HIV Screening of Pregnant Women. *MMWR* 2001; 50(19):32-35.
8. Essex, M., Kanki, P.J., Marlink, R., et al. (1990) Antigenic characterization of the human immunodeficiency viruses. *J Am Acad Dermatol* 22 : 1206-1210.
9. Essex, M., McLane, M.F., Lee, T.H. et al. (1983) Antibodies to cell membrane antigens associated with human T-cell leukemia virus in patients with AIDS. *Science* 220 : 859-862.
10. Gallo, R.C., Saluahuudin, S.Z., Popovic, M., et al. (1984) Frequent detection and isolation of cytopathic retroviruses (HTLV-III) from patients with AIDS and at risk for AIDS. *Science* 224 : 500-503.
11. Kenealy, W., Reed, D., Cybulsky, R., et al. (1987) Analysis of human serum antibodies to human immunodeficiency virus (HIV) using recombinant ENV and GAG antigens. *AIDS Res Human Retrovir* 3:95-105.
12. Kovacs, A., Xu, J., Rasheed, S., et al. (1995) Comparison of a rapid non-isotopic polymerase chain reaction assay with four commonly used methods for the early diagnosis of human Immunodeficiency Virus type 1 infection in neonates and children. *Pediatr Infect Dis J* 14 : 948-954.
13. CDC: Approved of a New Rapid Test for HIV Antibody. *MMWR* 1988; 37(24) 377-388.

ADVICE LINE

Further information can be obtained from www.clearview.com, your distributor or Inverness Medical Technical services on Tel: +44 1234 835959

Manufactured by Chembio Diagnostic Systems, Inc., Medford, NY for Inverness Medical Professional Diagnostics under issued patents U.S. 6,352,862; 6,534,320; 5,622,871; 5,656,503; 6,187,598; 4,956,302; 6,627,459; 5,602,040; 6,228,660; 6,818,455; 5,120,643; 5,714,389; 5,989,921; 6,485,982; and additional patents pending that are owned or licensed by a member of the Inverness Medical family of companies. Corresponding rights granted or pending elsewhere.

Manufactured by Chembio Diagnostic Systems, Inc. for Inverness Medical Professional Diagnostics under U.S. 5,935,864 and additional patents pending that are licensed from StatSure Diagnostic Systems, Inc., Framingham, MA. Corresponding rights granted or pending elsewhere.

 Consult instructions for use

 In vitro diagnostic medical device

 Do not reuse

 Manufactured by

 Contains sufficient for <n> tests

 Temperature limitation 8-30°C

 Catalogue Number

 Inverness Medical Professional Diagnostics, 331 S. 104th Street, Louisville CO 80027 USA

© 2007 Inverness Medical Professional Diagnostics
Clearview® is a registered trademark of the Inverness Medical family of products.

